



# **Dts-12**

## **ROLLER DOOR OPERATOR INSTALLATION MANUAL**

Comply to: SANS IEC 60 335-2-103  
NRCS Cert. no. 88934/002

**DTS SECURITY PRODUCTS CC**  
**P.O.BOX 3399**  
**EDENVALE**  
**1610**  
**TELEPHONE 086 1000 387**

<b>Spartan</b>	<b>+2711 392 5540 (H/O)</b>
<b>Pretoria</b>	<b>+2712 361 5528</b>
<b>Alberton</b>	<b>+2711 907 8846</b>
<b>Natal</b>	<b>+2731 916 4002</b>

[www.dtssecurity.co.za](http://www.dtssecurity.co.za)

**IMPORTANT! PLEASE READ THESE INSTRUCTIONS CAREFULLY PRIOR TO INSTALLATION OF THE ROLLER DOOR OPERATOR.**

This automatic opener has been designed to provide years of trouble free use. The opener will perform efficiently only if it is installed and operated correctly.

**READ THESE IMPORTANT SAFETY RULES FIRST.**

Keep garage door balanced. Sticking or binding doors must be repaired. Garage doors, door springs, brackets and their hardware are under extreme tension and can cause serious personal injury. **Do not attempt adjustment.** Call professional garage door installers.

Do not wear rings, watches or loose clothing while installing or servicing a garage door operator.

Installation and wiring must be in compliance with your local building and electrical codes.

**The safety reverse system** test is very important. Your garage door must reverse on a contact with a 5 to 10cm high object on the floor. Failure to properly adjust the operator may result in serious personal injury from a closing garage door. Repeat the test once a month and make any needed adjustments. (See Sensitivity adjustment).

DTS-12 operator has an electronic obstruction system that provides safe and reliable operation. It is however a legal requirement in some countries to also install a Photo-electric sensor across the door way. Please check this requirement with your local distributor.

Do not use the force adjustments to compensate for a binding or sticking garage doors. Excessive force will interfere with the proper operation of the Safety Reverse System or damage the garage door.

This unit should not be installed in a damp or wet space.

Disengage all existing garage door locks to avoid damage to garage door.

Install the lighted door Control Box (or any additional Push Buttons) in a location where the garage door is visible, but out of the reach of children. Do not allow children to operate push button(s) or remote control(s). Serious personal injury from a closing garage door may result from misuse of the operator.

**CAUTION:** Activate operator only when the door is in full view, free of obstructions and operator is properly adjusted. No one should enter or leave the garage while the door is in motion. Do not allow children to play near the door.

Disconnect electric power to the garage door operator before making repairs or removing covers.

**IMPORTANT:** Fix a caution label to the rear of the garage door as a reminder of safe operating procedures.

## Pre-Installation Notes

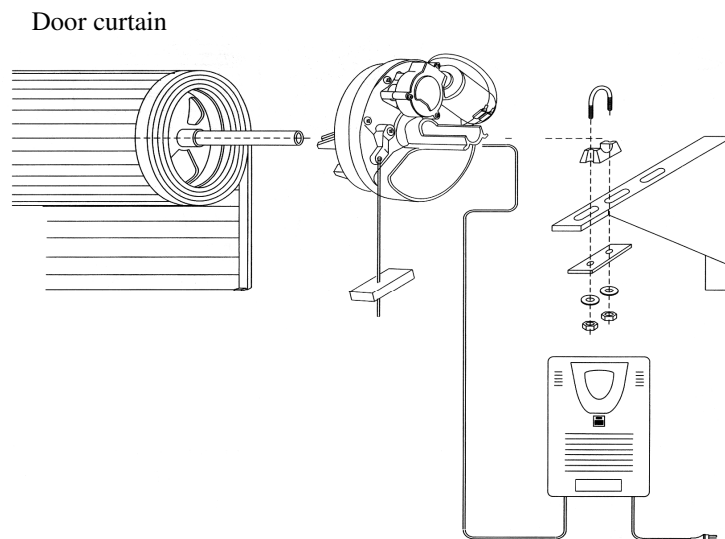

Right hand installation shown (inside garage looking out) Fig 1

Check that there is sufficient side clearance to fit the operator unit. It may be fitted to either the right or left hand side.

(1) Minimum side clearance:  
The minimum side clearance between door curtain and the inside edge of mounting bracket is 85mm;  
The minimum side clearance between door curtain and the outside edge of mounting bracket is 135mm.

(2) Recommended side clearance  
The recommended side clearance between door curtain and the inside edge of mounting bracket is 110mm;  
The recommended side clearance between door curtain and the outside edge of mounting bracket is 160mm.

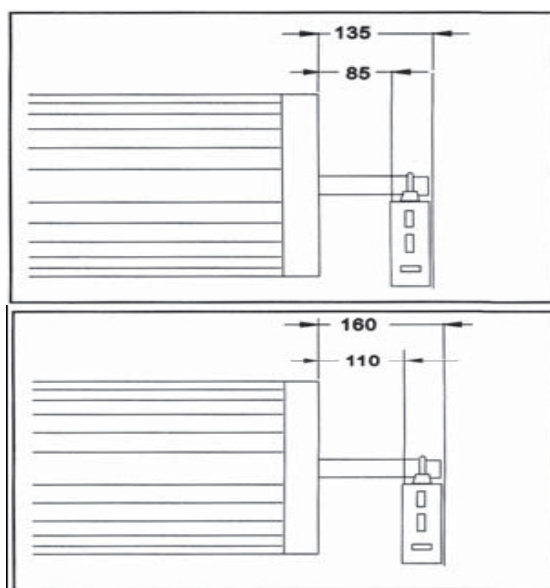

If the operator is being fitted at the same time as the new door installation, read these instructions in conjunction with the roller door installation instructions.

If the operator is being retro-fitted, make sure the door operates smoothly and is properly balanced.

**N.B.: SPECIAL CARE SHOULD BE TAKEN IF RE-TENSIONING OF THE DOOR IS REQUIRED.**

At no stage should you loosen both “U” bolts if door is under tension.

**IF THERE ARE ANY PROBLEMS PLEASE CONTACT YOUR LOCAL SUPPLIER OF THIS OPERATOR.**

## INSTALLATION INSTRUCTIONS

*Installation on the Krazi door and others where the door drum is more than 135mm from the centre shaft support bracket.*

1. Release the engage/disengage lever on the motor so that the motor runs free.
2. On the door support bracket carefully remove the door support hook
3. Carefully lift up the door and slide the motor over the centre shaft of the door. (fig.3)
4. Put the door back and refit the door support hook
5. Close the door so that the motor is visible.
6. Move the motor over the centre shaft and hook securely on the drum wheel of the door
7. Fit and secure the u-bolt, make sure it is fully tightened. The motor must not move on the shaft.
8. Use Tek screws to secure u-bolt bracket to centre shaft of garage door and make sure the motor does not move.

*Installation on Wispeco and others where the drum wheel door is less than 135mm from the centre shaft support bracket.*

1. Release the engage/disengage lever on the motor so that it runs free.
2. Make sure that there is enough space for installing the opener. It is required that the minimum distance from the shaft end to the wall is 135mm.
3. Please check carefully if the u-bolt on the other side of the door locks the centre shaft tightly. If not, carefully tighten it.
4. Move the door up and use a rope to bind the door in the middle.  
(Ref fig 2)
5. Use a prop or ladder to hold up the door at the motor end. Be careful not to scratch the surface of the door (ref to fig.5).
6. Remove the u-bolt carefully.
7. Move the bracket away from the wall. Make sure that the prop can hold the door up safely and securely.
8. Take the motor out of the box, put the motor along the centre shaft into the wheel of the door. Make sure that the motor hooks securely onto the drum wheel of the door.
9. Re install the bracket, if necessary check position.

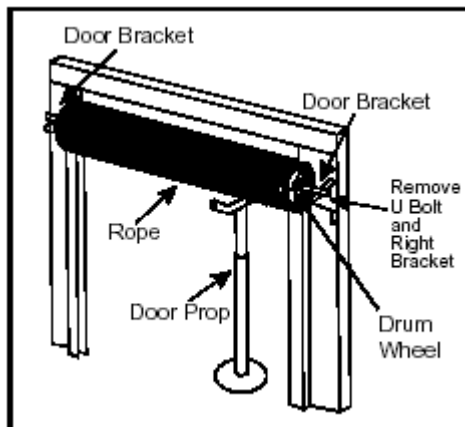

Fig 2

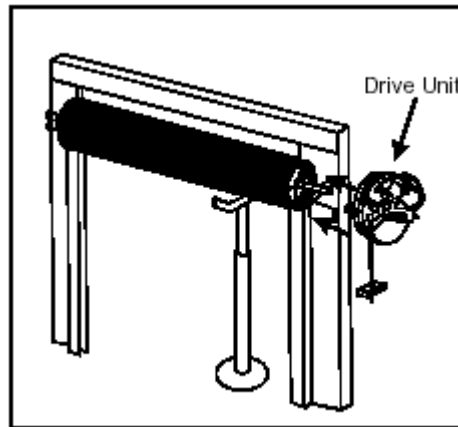

Fig 3

## New Door Installation

### STEP 1

Whilst the door roll is on the floor, rotate shaft backwards and forwards by hand and then release. This action will allow the roll to centralize itself on the shaft. (New installation only).

Figure 4

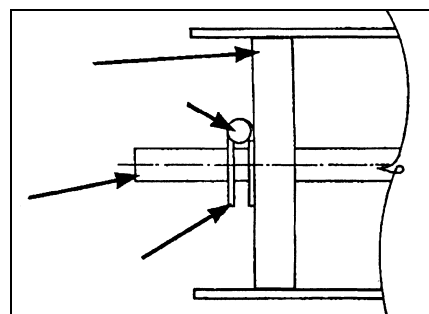

### STEP 2

Fit anti-coning collar TIGHT TO DRUM at opposite end of curtain to the motor using M8 Dome Head Screw and M8 Nyloc Nut as required. Figure 4.

Figure 5

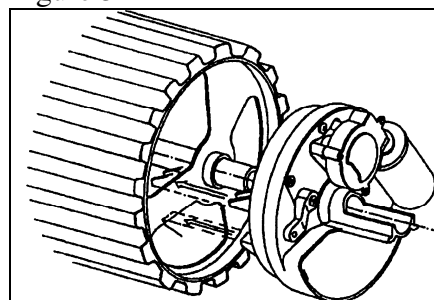

### STEP 3

Slide drive unit onto shaft as shown Figure 5. Ensuring drive lugs engage fully with the narrowest spoke on drum wheel.

Figure 6

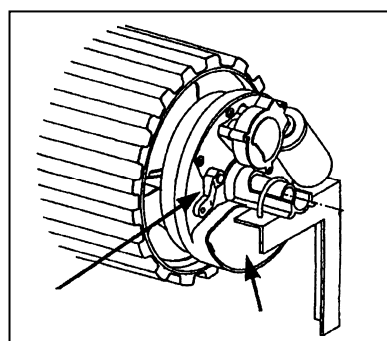

### **N.B.: Right-hand installation shown (inside looking out)**

Lift door onto mounting brackets (ensuring curtain roll is correct way round) centralize curtain roll with opening. Refer to door installation instructions. (New installations only).

Ensure motor assembly is fully engaged with drum wheel spokes. Clamp shaft to mounting brackets using “U” Bolts supplied. (Use “U” bolt in opener pack for MOTOR end). See Figure 6.

Disengage the motor drive by pulling the manual release lever downwards. See Figure 6.

Tension door and complete door installation as per Door Installation Instructions. Ensure door is correctly balanced and is not binding or sticking within vertical tracks.

Ensure locking bars (if fitted) are moved to the retracted (unlocked) position and keys removed from the lock.

Mount control Unit approximately 1.6m from the floor out of the reach of children. Use No. 4x1” self-tapping screws and rawlplugs. Ensure aerial is clear of all steel supports and coiled electrical leads. Fit plug from motor unit into bottom of Control Box.

Connect the control unit power cord to an adjacent socket. Ensure that the socket is properly earthed.

## SETTING TOP AND BOTTOM LIMITS

**N.B.: Right Hand Installations only. If left hand, limit switch will be reversed.**

### STEP 1

Remove Limit Switch Cover Plate (See Figure 6) by carefully pressing off with a small screwdriver.

### STEP 2

Top limit cam “T” controls open position of door.  
Bottom limit cam “B” controls closed position of door.

### STEP 3

Slightly loosen the three retaining screws so that the cams can be easily moved. (See Figure 7).

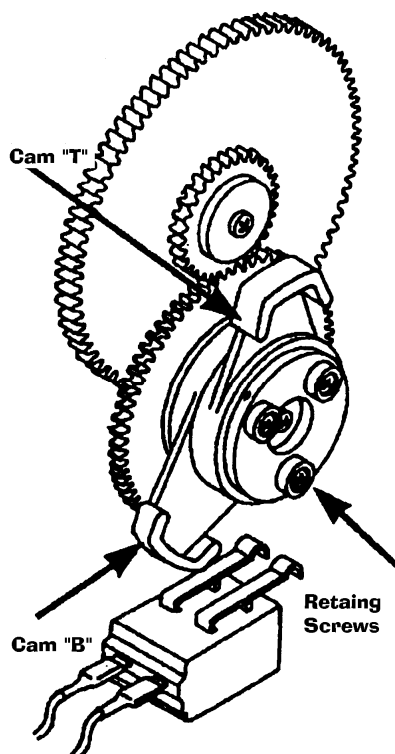

Figure 7

### STEP 4

Ensure that the manual release lever is still in the “disengaged” position, and manually raise the door until it is approx 100mm from the top stop position.

### STEP 5

Rotate cam “T” (in the same direction that it was moving as you were manually raising the door) so that it actuates the top Limit Switch.

### STEP 6

Manually lower the door until it is touching the ground.

### STEP 7

Rotate cam “B” (in the same direction that it was moving, as you were manually lowering the door) so that it actuates the bottom Limit Switch.

### STEP 8

Tighten the three retaining screws so that the cams will not move.

### STEP 9

Manually position door to halfway and re-engage the motor drive by moving the manual release lever to the “engage” position.

N.B.: Door can now only be operated electrically, not manually. If you wish to return to manual operation, ensure power is switched off and move lever to “disengage” position.

Figure 8

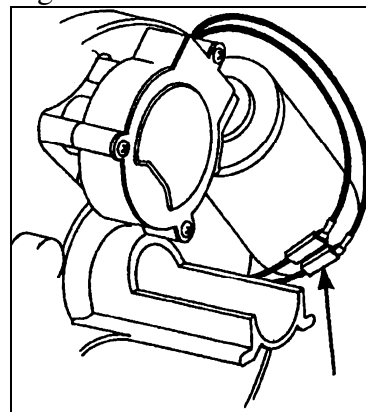

### STEP 10

Switch on power to the Control Box and operate the door from PUSH button on the Control Box.

**IMPORTANT:** When the door is traveling in the “Up” position, hold bottom rail. The door should overload and stop. If it does not, see that motor direction is correct.

You will need to re-adjust the Limit Cams as they will be working in a different direction.

Figure 9

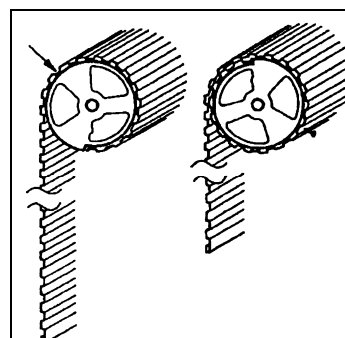

### STEP 11

Press Button on Control Box Front and check closing and stopping position.

- i) Door fully closed
- ii) Door slightly closed

### STEP 12

If you are achieving the desired stop position, then replace the Limit Switch Cover Plate. If not, then reset the Limit Cams (Steps 2 to 9) after first turning off the mains power.

### STEP 13

Once the limits have been set, fit the additional security screws (if required) with the door in manual mode. With the door fully closed, mark the panel at the first point where the curtain roll touches the drum wheel, on both ends of the curtain (See figure 9).

Raise the door slightly so that the marks can be seen and accessed from inside the garage. Fit the security screws through the bottom of a corrugation and into the plastic flange of the drum wheel, on both ends of the curtain. Tighten securely.

**WARNING! – Do not run door on power through its full travel until the limits are correctly set.**

## Control box set up

### Remove cover on front of control box

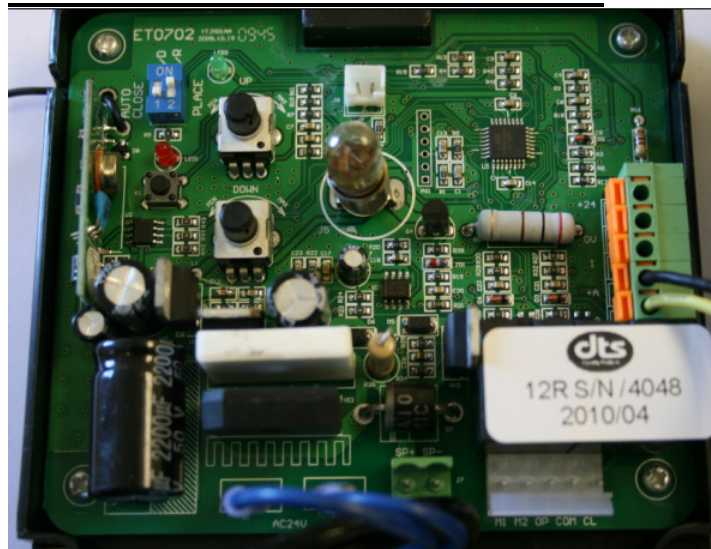

#### 1. Wiring diagram

J1, J2	(AC24V)	: Transformer output
J3	A, A+, I, OV, +24	: Manual push button / Receiver Input NO / Infra red beam / Common & DC auxiliary voltage.
J7	SP+, SP-	: Battery Backup Connector
J8	M1, M2, OP, COM, CL	: Motor & Limit wires
LAMP		: 36V 1.5W light socket

#### 2. Auto close option

Dipswitch 1 OFF-E (Enable) position: auto close feature is on – **Infra red beam must be fitted.**  
Dipswitch 1 ON-D (Disable) position: auto close feature is off.

#### 3. Right hand and left hand installation.

Dipswitch 2 on “R” position is for right hand installation.  
Dipswitch 2 off “L” position is for left hand installation.

#### 4. Sensitivity adjustment

- 1) Adjust pot “DOWN” for close traveling sensitivity, clockwise is for more force and anti-clockwise for less force.
- 2) Adjust pot “UP” for open traveling sensitivity, clockwise is for more force and anti-clockwise for less force.

Whilst the door is traveling turn the obstruction sensitivity pot slowly until an overload condition occurs i.e. door going up stops before reaching the set top limit or door going down auto reverses before reaching set bottom limit. Cycle the door a few times ensuring an overloading condition is not registered during normal operation.

5. **Battery Backup (Optional)** (If your battery back-up has a **3** plug connection, have it changed). Plugs into SP+ & SP-.

#### **PROGRAMMING TRANSMITTERS TO CONTROL BOX** (Max 20)

Press and release K1 learning button below the red LED, the red LED will light up, then press the transmitter once & the red LED will go off, press the same transmitter again, the red LED will flash fast 8 times. The transmitter is now programmed.

- For more transmitters (max. 20), code them the same as above.
- If the red LED gives 4 double flashes on pressing the K1 button, the receiver is full.



### **To master delete all codes**

Press and hold the K1 learning button, the LED will flash 10 times, all transmitter codes held in the memory have been erased.

### **Wiring for external receivers.**

#### **PCB to Receiver**

+24 24 Volt

- Neg.

+A N/O

A Com.

(Power for any 24 volt DC externals can also be taken from SP- (Neg.) and SP+ (Pos.)

(If the receiver and the cover red push button don't work, power down for approximately 5 seconds then re-apply power).

**N.B.: If a transmitter is lost or stolen please master delete the receiver and re-learn all the transmitters again.**

## **OWNER'S MANUAL**

### **DOOR OPERATION**

A roller door equipped with a roller door operator may be operated by any of the following two methods:

By using the hand held Transmitter;

By depressing the push button on the control box. (Mounted on the wall)

### **WARNING!**

Ensure that the Centre Lift Lock is not engaged when the Drive Unit is in the automatic position.

### **Manual Operation**

In the case of a power failure, the drive unit has an easily accessible manual release lever; the door could be opened manually.

### **Obstruction Detection**

During an open cycle if an obstruction is detected the door will stop.

During a closing cycle if an obstruction is detected the door will reverse to the open position.

The sensitivity or the amount of force required to cause an obstruction detection is fully adjustable.

### **Courtesy Light**

An internal courtesy light is housed within the control box enclosure. This is activated during an open or close cycle and will stay illuminated for approximately 60 seconds.

### **Automatic Closing.**

When auto close is selected, the door will close after 60 seconds. Please do not use this function without installing Photo-beam.

### **Photo-electric sensor**

The operator includes an interface for the connection of a photo-beam sensor.

The Photo-beam sensor can be supplied as an accessory option.

## **OPERATING CONTROLS**

- a. Control Box Push Button  
Pressing this button will open, close or stop the door.
- b. Hand transmitter  
Pressing the programmed transmitter will open, close and stop the door.

The hand transmitter is manufactured using the latest surface mount technology and incorporates 4 functional buttons. This enables the user to remotely control up to 4 separate operators from the one transmitter.

## **FAULT FINDING**

### **DOOR WILL NOT OPERATE FROM**

#### **A) Control Box**

- Check power is on to Control Unit (Red L.E.D. illuminated).
- IF NOT, check mains plug and fuse.
- Plug fully engaged on top of Control Box.
- Motor wiring connections properly engaged.
- Manual release lever in “engaged” position.
- Limit Switch cams correctly set i.e. upper Limit Switch for fully open position, lower limit switch for fully closed position.
- Move door manually to half-closed position and try again.
- Try operation with Hand Transmitter.

#### **B) Handheld Transmitter**

- Check door operates correctly using the Push Button on Power Head to prove system is OK.
- Try recoding Transmitter.
- Check battery in Transmitter is correctly fitted. L.E.D. should illuminate.
- Try new battery.
- Move aerial manually and try in different orientations, keeping it away from steel structures and electrical cables.

### **DOOR OPERATES BUT FAILS TO FULLY OPEN OR REVERSES BEFORE CLOSING.**

- Check manual operation for correct balance, not binding. Adjust if necessary.
- Spray silicone lubricant into tracks, **do not grease**.
- Check/adjust safety sensitivity setting.
- Check Limits.

### **BANGS HARD ON TRACK STOPS WHEN FULLY OPEN**

- Check top (Cam “T”) Limit Switch setting.
- Adjust if necessary.

### **BANGS HARD ON GROUND AND REVERSES WHEN FULLY SHUT**

- Check bottom (Cam “B”) Limit Switch setting.
- Adjust if necessary.

### **DOOR FAILS TO TRAVEL DOWN FROM OPEN POSITION – MOTOR RUNS AND ROLLER DOOR BALOONS**

- Check door curtain has smooth line of entry into tracks, as near vertical as possible.
- Check door tension is not too great, reduce spring tension if necessary. If the above does not cure the problem, then the door may require a weight bar to be fitted.

### **SHORT RANGE REMOTE CONTROL**

- Remote Control should give minimum of 6m range.
- Check battery is correctly fitted in Transmitter.
- Try new battery.
- Move aerial and try in different orientations, keeping away from steel structures and electrical cables.

### **DOOR OPERATES BUT FAILS TO FULLY OPEN BUT REVERSES TO CLOSED POSITION.**

- Change Dip switch 2 on.
- Reset Limits.
- Re-adjust Sensitivity Adjustment.

## **POWER FAILURE**

### **To disengage / engage**

Pull manual release lever downwards. (Refer fig 10 below)

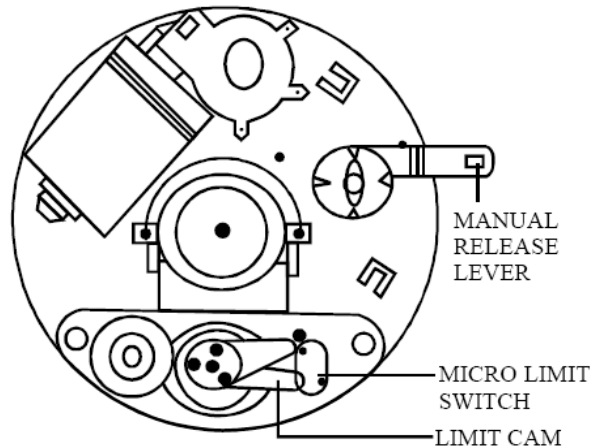

Figure 10

### **Technical Specifications**

INPUT VOLTAGE:	220VAC $\pm$ 10% 50 Hz (110VAC 60Hz or 127VAC 60Hz available on request) Single Phase
TRANSFORMER SPEC:	Primary Voltage            220VAC $\pm$ 10% Secondary Voltage        24 VAC
WORKING CIRCUMSTANCE:	TEMPERATURE:            -20 C – 70 C RELATIVE HUMIDITY: <90%
MOTOR SPEC:	Motor Type                Permanent Magnet D.C. Motor Voltage                      24V DC
CONTROL BOARD SPEC:	Control Board Voltage    24V DC / 5V DC Light Glove Voltage      36V 1.5W Receiver specification (Built in)                  Receiver type FSK AM RF Frequency 433MHz/315MHz Control distance 50m max.
TRANSMITTER SPEC:	Carrier Frequency        433 MHz / 315 MHz Current Consumption      50 mA (approx) Battery Voltage            12 Volts A23 battery Coding Format               Rolling Code (7.38x10 Code Combinations)

### **ACCESSORY OPTIONS**

Additional remote control transmitter  
Infrared beam Additional safety feature  
Manual release lock  
External receiver.

## **Warranty.**

- **All goods sold by DTS Security carry a 12 month factory warranty from date of invoice.**
- **All goods are warranted to be free from faulty components and manufacture.**
- **Faulty goods will be repaired or replaced at the sole discretion of DTS Security Products, free of charge.**
- **This warranty is subject to the goods being returned to the premises of DTS Security Products.**
- **This warranty excludes lightning damage, insect damage and damage caused by faulty installation.**
- **In the event of the goods being supplied by dealer, merchant, agent or duly appointed installer of DTS Security Products, the claim must be directed to that supplier.**
- **The carriage of goods is for the customer's account.**
- **This warranty is only valid if the correct installation and application of goods, as laid out in the applicable documentation accompanying said goods, is adhered to.**
- **All warranty claims must be accompanied by the original invoice.**
- **The liability of DTS Security Products and / or their distributors is limited as herein set out DTS Security Products and / or their distributors will not be liable for consequential or incident damages howsoever arising.**